



MOTORCYCLE HEAVY DUTY FRONT WHEEL CHOCK

MODEL NO: **FPS7.V2**

Thank you for purchasing a Sealey product. Manufactured to a high standard, this product will, if used according to these instructions, and properly maintained, give you years of trouble free performance.

IMPORTANT: PLEASE READ THESE INSTRUCTIONS CAREFULLY. NOTE THE SAFE OPERATIONAL REQUIREMENTS, WARNINGS & CAUTIONS. USE THE PRODUCT CORRECTLY AND WITH CARE FOR THE PURPOSE FOR WHICH IT IS INTENDED. FAILURE TO DO SO MAY CAUSE DAMAGE AND/OR PERSONAL INJURY AND WILL INVALIDATE THE WARRANTY. KEEP THESE INSTRUCTIONS SAFE FOR FUTURE USE.



Refer to instructions



Wear safety footwear

1. SAFETY

- WARNING! Before use, ensure that there is nothing attached to the front forks or the fairing of the motorcycle, that will foul on the chock.**
- ✓ Maintain the chock in good condition (use an authorised service agent).
- ✓ Replace or repair damaged parts. Use genuine parts only. Unauthorised parts may be dangerous and will invalidate the warranty.
- ✓ Locate the chock in a suitable area. Keep area clean and tidy and free from unrelated materials and ensure that there is adequate lighting. Also ensure that the floor/ground is level and strong enough (preferably concrete) to take the weight of the chock and the motorcycle.
- ✗ **DO NOT** mount the chock on tarmac/adam, as the surface may be unstable.
- ✓ Ensure that the clamps are free from oil and grease before positioning a motorcycle in the chock.
- ✓ Keep the chock clean for the best and safest performance.
- ✓ Maintain correct balance and footing whilst positioning the motorcycle in the chock.
- ✓ Ensure that the floor is not slippery and wear non-slip shoes.
- ✓ Ensure that the motorcycle is adequately secured to the chock if to be used for transportation purposes.
- ✓ Keep children and unauthorised persons away from the work area.
- ✗ **DO NOT** use the chock for a purpose it is not designed to perform.
- ✗ **DO NOT** operate the chock if it is damaged.
- ✗ **DO NOT** use the chock when you are tired or under the influence of alcohol, drugs or intoxicating medication.
- ✗ **DO NOT** allow untrained persons to use the chock.
- ✗ **DO NOT** make any modifications to the chock.
- ✓ Before removing a motorcycle from the chock, ensure that there are no obstructions or persons in the path of the motorcycle.
- WARNING: The warnings, cautions and instructions in this manual cannot cover all possible conditions and situations that may occur.**
- ✓ **It must be understood that common sense and caution are factors which cannot be built into this product, but must be applied by the operator.**

2. INTRODUCTION

Tubular wheel chock supports the front wheel of the motorcycle when in transit or storage. Fully adjustable to fit wheels 15"-21"(380-525mm). Features a pivot clamp which locks the front wheel securely by the motorcycle weight. Chock can be used freestanding or fixed to any hard surface.

3. SPECIFICATION

Minimum/Maximum Tyre Width: 50-130mm
Minimum/Maximum Wheel Diameter:..... 15"-21"(380-525mm)
Model No: FPS7
Nett Weight: 8.08kg.

4. ASSEMBLY

- 4.0.1. Connect tyre stop upper pole (3) and lower pole (4), aligning the holes in the desired position. Secure in place with the R clip for pole connection (6). (fig.1).

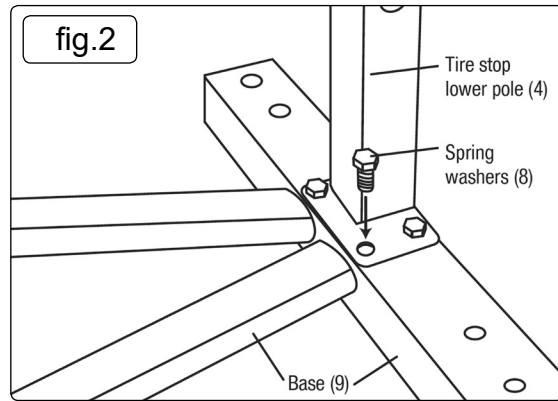
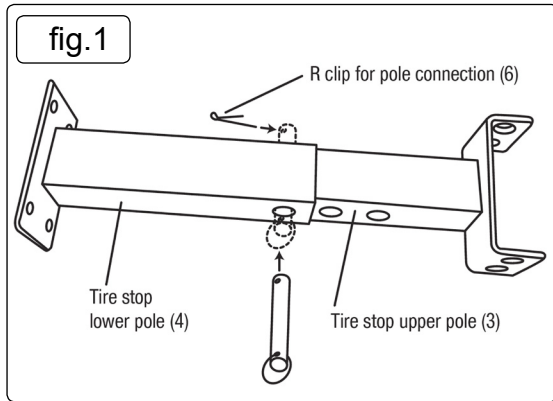

- 4.0.2. Secure the tyre stop lower pole (4) to the base (9) using the four bolts and spring washers (8). (fig.2).

- 4.0.3. Place the tyre stop (1) on upper pole (3), aligning the holes in the desired position. Secure in place with the tyre stop bolt, lock washer and nut (2). (fig.3).

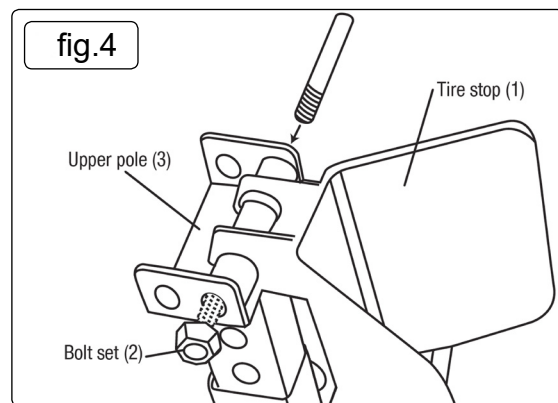
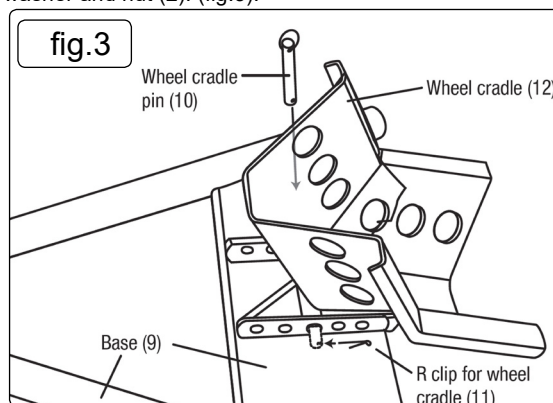

- 4.0.4. Place the wheel cradle (12) at the bottom end of the base (9), aligning the holes in the desired position. Secure in place with the wheel cradle pin (10) and R clip for wheel cradle (11). (fig.4).

5. INSTALLATION

5.1. MOUNTING POINTS. (fig.5).

- 5.1.1. Identify the chock mounting points.

5.2. PERMANENT INSTALLATION.

- 5.2.1. Choose the installation site carefully so that there is good access to both insert and extract the motorcycle from the chock.

- 5.2.2. Ensure that the motorcycle and chock **DO NOT** become a hazard.

- 5.2.3. Use anchor bolt fixings to secure the chock to a solid concrete surface.

5.3. INSTALLATION FOR TRANSPORTATION.

- 5.3.1. When used for the transportation of motorcycles, the chock must be firmly bolted to the floor of the vehicle using suitable fixings. Check the underside of the floor panel before drilling any holes. Make sure that you **DO NOT** strike any important vehicle parts.

- 5.3.2. Ensure that the vehicle has the capacity to take the weight of the motorcycle(s) plus the chock(s).

- 5.3.3. When using the chock for transportation purposes, the front wheel of the motorcycle must be securely strapped to the chock.

- 5.3.4. For additional security, consideration should also be given to securing the rear wheel.

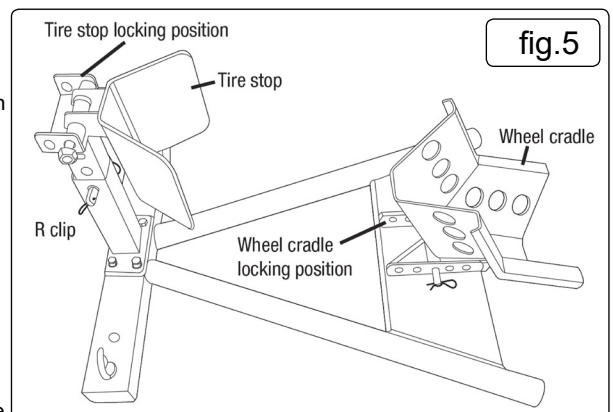

6. OPERATION

6.1. ADJUSTING THE CLAMPS (FIG.5).

- 6.1.1. The upper clamp has 2 locking positions and the pivot clamp has 5 locking positions. To adjust the clamps, extract the 'R' clip and withdraw the pin. Move the clamp to the desired position, insert the pin and retain with the 'R' clip.

- 6.1.2. To obtain the optimum fit for differing sizes of motorcycle wheel, adjust the positions of the clamps and then test as necessary.

6.2. POSITIONING MOTORCYCLE IN THE CHOCK.

- 6.2.1. With the pivot clamp in the open position as shown in fig.5, align the motorcycle with the chock.

- 6.2.2. Push the motorcycle firmly into the chock so that the front tyre runs through the tapered part of the pivot clamp.

- 6.2.3. As the weight of the wheel passes over the pivot clamp, it will cause the clamp to flip over. The front of the tyre will be supported by the upper clamp and the rear of the tyre by the pivot clamp.

- 6.2.4. Check that the motorcycle is stable within the chock before leaving it. If the wheel is loose, or too high in the chock, extract the motorcycle from the chock and adjust the positions of the clamps until the optimum fit is achieved (see section 4.3).

6.3. REMOVING MOTORCYCLE FROM THE CHOCK.

- 6.3.1. More effort will be required to remove the motorcycle from the chock. Ensure that the space into which the motorcycle will move is free

from obstructions and people.

6.3.2. Take a firm stance and hold the motorcycle handlebar grips.

6.3.3. Pull back the motorcycle with sufficient force to overcome the hold of the pivot clamp and release the motorcycle from the chock.



ENVIRONMENT PROTECTION

Recycle unwanted materials instead of disposing of them as waste. All tools, accessories and packaging should be sorted, taken to a recycling centre and disposed of in a manner which is compatible with the environment. When the product becomes completely unserviceable and requires disposal, drain any fluids (if applicable) into approved containers and dispose of the product and fluids according to local regulations.

Note: It is our policy to continually improve products and as such we reserve the right to alter data, specifications and component parts without prior notice.

Important: No Liability is accepted for incorrect use of this product.

Warranty: Guarantee is 12 months from purchase date, proof of which is required for any claim.

Sealey Group, Kempson Way, Suffolk Business Park, Bury St Edmunds, Suffolk. IP32 7AR



01284 757500



01284 703534



sales@sealey.co.uk



www.sealey.co.uk