

SEALEY

OIL FREE LOW NOISE AIR COMPRESSOR 50 & 100L DIRECT DRIVE 2 X 2HP

MODEL NO: **SAC5001S SAC10001S**

Thank you for purchasing a Sealey product. Manufactured to a high standard, this product will, if used according to these instructions, and properly maintained, give you years of trouble free performance.

IMPORTANT: PLEASE READ THESE INSTRUCTIONS CAREFULLY. NOTE THE SAFE OPERATIONAL REQUIREMENTS, WARNINGS & CAUTIONS. USE THE PRODUCT CORRECTLY AND WITH CARE FOR THE PURPOSE FOR WHICH IT IS INTENDED. FAILURE TO DO SO MAY CAUSE DAMAGE AND/OR PERSONAL INJURY AND WILL INVALIDATE THE WARRANTY. KEEP THESE INSTRUCTIONS SAFE FOR FUTURE USE.



Refer to instruction manual



Warning: Electricity



Warning: Hot surface



Wear ear protection



Indoor use only



Check oil level before first use



DO NOT open air cock before air hose attached



Wear eye protection



Warning: Auto Start

1. SAFETY

1.1. ELECTRICAL SAFETY

WARNING! It is the responsibility of the owner and the operator to read, understand and comply with the following: You must check all electrical products before use to ensure that they are safe. You must inspect power cables, plugs, sockets and any other connectors for wear or damage. You must ensure that the risk of electric shock is minimised by the installation of appropriate safety devices. A Residual Current Circuit Breaker (RCCB) should be incorporated in the main distribution board. We also recommend that a Residual Current Device (RCD) is used. It is particularly important to use an RCD with portable products that are plugged into a supply which is not protected by an RCCB. If in any doubt consult a qualified electrician. You must also read and understand the following instructions concerning electrical safety:

1.1.1. The Health & Safety at Work Act 1974 makes owners of electrical appliances responsible for the safe condition of those appliances and the safety of the appliance operators. **If in any doubt about electrical safety, contact a qualified electrician.**

1.1.2. Ensure that the insulation on all cables and on the appliance is safe before connecting it to the power supply.

1.1.3. Ensure that cables are always protected against short circuit and overload.

1.1.4. Regularly inspect power supply cables and plugs for wear or damage and check all connections to ensure that none are loose.

1.1.5. Important: Ensure that the voltage marked on the appliance matches the power supply to be used and that the plug is fitted with the correct fuse.

▲ DANGER! If the power cable for this equipment is damaged, it must be replaced by the manufacturer or its after-sales service or similarly trained personnel to avoid danger.

* **DO NOT** pull or carry the appliance by the power cable.

* **DO NOT** pull the plug from the socket by the cable.

* **DO NOT** use worn or damaged cables, plugs or connectors. Immediately have any faulty item repaired or replaced by a qualified electrician.

1.1.6. Over/current Protection: The user has to make provision for the installation of the over-current protection of the power circuit.

1.2. Electrical disconnecting device: The user has to make provisions for the installation of the electrical disconnecting device of the power circuit. The supply disconnection device is to be in accordance with EN 60204-1:2006.

NOTE: If using a transformer to supply the compressor, it must be rated at a minimum of 2kVA to allow the compressor to run efficiently.

GENERAL SAFETY

✓ Before you connect the equipment to the mains supply make sure that the data on the rating plate are identical to the mains data .

✓ Familiarise yourself with the application and limitations of the compressor.

✓ Ensure the compressor is in good order and condition before use. If in any doubt **DO NOT** use the unit and contact your Sealey Stockist.

✓ Operation must be with all guards, covers, lids and enclosures correctly in place.

✓ Fully assemble the compressor before using for the first time.

✓ The concentration of processed gases that can displace breathing air shall be kept within acceptable levels. Reference EN 12021 for acceptable levels of contaminants in breathing air.

✓ Remove from mains supply when performing maintenance or inspections.

WARNING! Item must be serviced by an authorised agent. **DO NOT** tamper with or attempt to adjust pressure switch or safety valve.

* **DO NOT** carry out any welding operations on any pressurised part of the vessel.

✓ Before moving, or maintaining the compressor ensure it is unplugged from the mains supply and that the air tank pressure has been vented.

✓ Maintain the compressor in good condition and replace any damaged or worn parts. Use genuine parts only. Unauthorised parts may be dangerous and will invalidate your warranty.

✓ Delivery hoses should be fitted with a safety cord.

✓ It is essential to use separators, water traps and drains which process the liquids produced by the compressor system is put into operation.

✓ The compressor may only be used in suitable rooms (with good ventilation and an ambient temperature from +5°C to +40°C). Ensure there is no dust, acids, vapours, explosive gases, or inflammable gases in the room. The air intake should be from a clean, outside air source.

✓ Read the instructions relating to any accessory to be used with this compressor. Ensure the safe working pressure of any air appliance used exceeds compressors output pressure.

✓ Ensure the safe working pressure of any air appliance used exceeds compressors output pressure. If using a spray gun, check that the area selected for spraying is provided with an air change system/ventilation.

✓ Ensure the air supply valve is turned off before disconnecting the air supply hose to move a transportable compressor use the handle only. Lift the compressor so that the front leg gives enough clearance for manoeuvring but maintain unit's centre of gravity in front of

- the wheels. **DO NOT** attempt to lift or move the compressor by any other means.
- ✓ Use the compressor in a well ventilated area and ensure it is placed on a firm surface.
- ✓ Keep tools and other items away from the compressor when it is in use, and keep area clean and clear of unnecessary items.
- ✓ Ensure the air hose is not tangled, twisted or pinched.
- ✓ Keep children and unauthorised persons away from the working area.
- ✓ Only move the compressor by the handle (if portable).
- ✗ **DO NOT** dis-assemble compressor for any reason. The unit must be checked by qualified personnel only.
- ✗ **DO NOT** use the compressor outdoors, or in damp, or wet, locations.
- ✗ **DO NOT** operate within the vicinity of flammable liquids, gases or solids.
- ✗ **DO NOT** touch compressor cylinder, cylinder head or pipe from head to tank as these may be hot.
- ✗ **DO NOT** use this product to perform a task for which it has not been designed.
- ✗ **DO NOT** deface the certification plate attached to the compressor tank.
- ✗ **DO NOT** cover the compressor or restrict air flow around the unit whilst operating.
- ✓ **DANGER! DO NOT** direct the output jet of air towards people or animals.
- ✗ **DO NOT** operate the compressor without an air filter.
- ✗ **DO NOT** allow anyone to operate the compressor unless they have received full instructions.
- **WARNING!** The air tank is a pressure vessel and the following safety measures apply:
 - ✗ **DO NOT** tamper with the safety valve, **DO NOT** modify or alter the tank in any way and **DO NOT** strap anything to the tank.
 - ✗ **DO NOT** subject the tank to impact, vibration or to heat and **DO NOT** allow contact with abrasives or corrosives.
- ✓ Drain condensation from tank daily and inspect inside walls for corrosion every three months and have a detailed tank inspection carried out annually. The tank shell must not fall below the certified thickness at any point.
- **WARNING!** If an electrical fuse blows, ensure it is replaced with an identical fuse type and rating.
- ✓ When not in use, store the compressor carefully in a safe, dry, childproof location.
- ✓ When the compressor is not in use, it should be switched off, disconnected from the mains supply and the air drained from the tank.
- ✓ Under the PRESSURE SYSTEMS SAFETY REGULATIONS 2000 it is the responsibility of the owner of the compressor to initiate a system of inspection that both defines the frequency of the inspection and appoints a person who has specific responsibility for carrying out the inspection.

2. INTRODUCTION

All models feature aluminium cylinder heads with cast iron cylinders giving added resistance to wear. Fitted with fully automatic pressure cut-out switches and twin gauges displaying tank and working pressures. Pump heads directly coupled to heavy-duty induction motors for reliable and quiet operation. Precision welded receiver tanks manufactured to meet Pressure Vessel Directive. The benefits of oil free compressors include: Easy maintenance, reduced noise levels, better efficiency, quieter when running and no oil contamination in the air supply.

3. SPECIFICATION

MODEL NO:	SAC5001S	SAC10001S
Air Displacement cfm(L/min):	19.7(558)	19.7(558)
Maximum Free Air Delivery cfm(L/min):	9.33(264)	10.13(287)
Maximum Pressure:	116psi(8bar)	116psi(8bar)
Minimum Rated Supply:	13A	13A
Motor Output:	2hp (x2)	2hp (x2)
Noise Level:	86dB(A) LwA/ 65dB(A) LpA	86dB(A) LwA/ 65dB(A) LpA
Outlet:	Quick Release Coupling	Quick Release Coupling
Phase:	1ph	1ph
Plug Type:	3-Pin BS	3-Pin BS
Power Supply Cable Length:	1.4m	1.4m
Receiver Capacity:	50L	100L
Size (W x D x H):	750 x 400 x 630mm	460 x 1010 x 770mm
Supply:	230V/13A	230V/13A
Weight:	43.9kg	63.5kg

Additional specification:

Short circuit current rating each incoming power supply: 14A
 Type of distribution system in the system: TT
 Full load current for each incoming supply: 11.4A
 Intended media: Air
 Inlet intermediate pressure and temperatures: 10bar
 Inlet discharge pressure and temperatures: 10bar
 Maximum pressure ratio: 10bar
 Pressure limits of the lubrication system: N/A
 Temperature limits of the lubrication system: N/A
 Maximum speed of the unit: 2900rpm
 Minimum speed of the unit: 2800rpm
 Noise Test Code: EN ISO 2151:2008

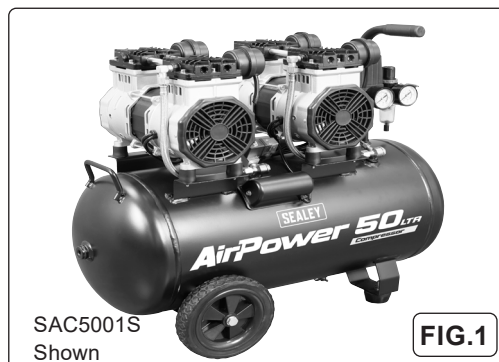

4. PREPARATION

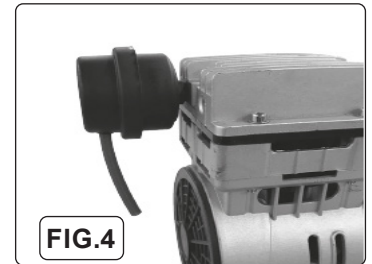
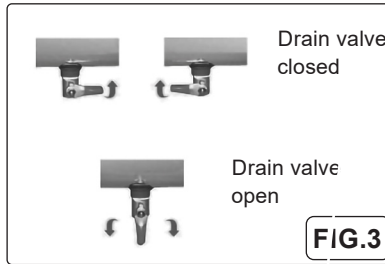
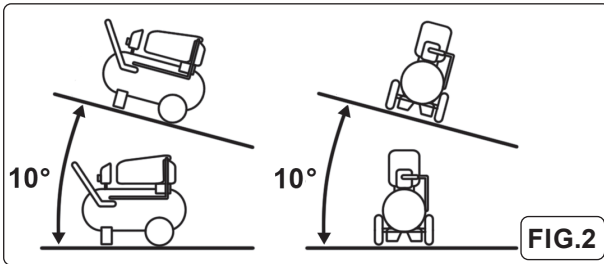

- 4.1. Remove the compressor from its packaging and inspect for any shortages or damage.
- 4.2. Confirm that the 230V voltage corresponds with the voltage shown on the compressor data plate.
- 4.3. To attach the castor wheels to the bracket located on the bottom of the tank using the supplied fixings (fig.1):
 - 4.3.1. Undo the nut and remove the washer from threaded shaft.
 - 4.3.2. Pass threaded shaft through the bracket, replace the washer and tighten the nut.
 - 4.3.3. Insert a bolt through the wheel.
 - 4.3.4. Pass through the tank wheel bracket and tighten the nut.
- 4.4. SAC10001S - Locate the handle into the mounting tubes and fix in place using the supplied fixings (fig.5).
- 4.5. The compressor should be installed on a flat surface, or one that does not exceed 10° either transversely or longitudinally, (see fig.2) and should be in a position that allows good air circulation around the unit.
- 4.6. If not already fitted, screw the air filter holders into the inlet ports (fig.4).

5. OPERATION

- ❑ **IMPORTANT:** Take care when selecting tools for use with the compressor. Air tool manufacturers normally express the volume of air required to operate a tool in cubic feet per minute (cfm). This refers to free air delivered by the compressor ('air out') which varies according to the pressure setting. Do not confuse this with the compressor displacement which is the air taken in by the compressor ('air in'). 'Air out' is always less than 'air in' due to losses within the compressor and so it is important that, before choosing equipment, you study the 'Free Air Delivery' figures shown in the Specification Chart.
 - ❑ **WARNING! ENSURE THAT YOU HAVE READ, UNDERSTOOD AND APPLIED SECTION 1 SAFETY INSTRUCTIONS.**
- 5.1. Make sure that the main switch (fig.5.1) is 'OFF' (down).
 - 5.2. Fit delivery hoses with safety cords to avoid whipping.
 - 5.3. Ensure that the tank drain valve is closed (fig.3).
 - 5.4. Connect the air tool required to the compressor via an air line connected to the air outlet.
 - 5.5. Plug the mains plug into the mains supply and start the compressor by pulling up the main switch (fig.5.1).
 - 5.6. Allow the pressure in the tank to rise to the maximum at which point the compressor will automatically cut out. Tank pressure is shown on the larger gauge (fig.5.6).
 - 5.7. Begin to gradually open the regulator by turning the knob clockwise (fig.5.2) until small gauge registers the required operating pressure specified for the tool to be used. Always **adjust up** to the required pressure rather than down from a higher pressure. The required setting, once achieved, can be locked by screwing the locking ring (fig.5.3) up tight underneath the adjusting knob.
 - 5.8. You can now begin to use the tool. The compressor will operate automatically

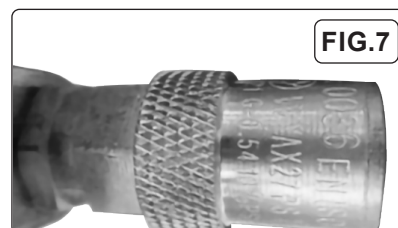
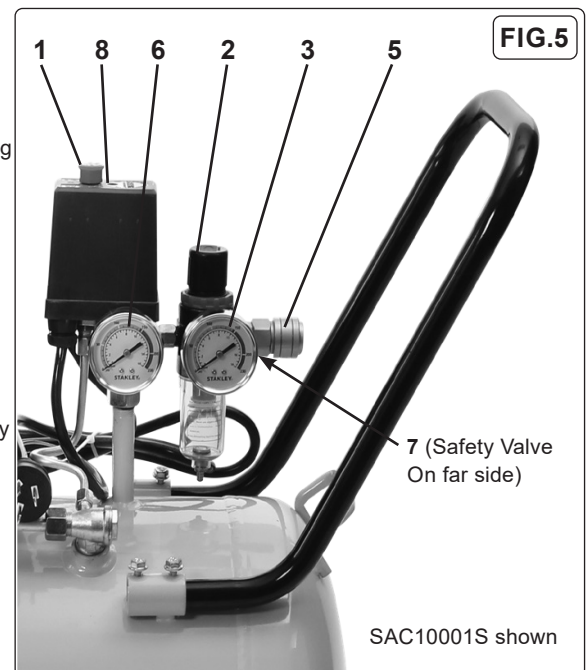
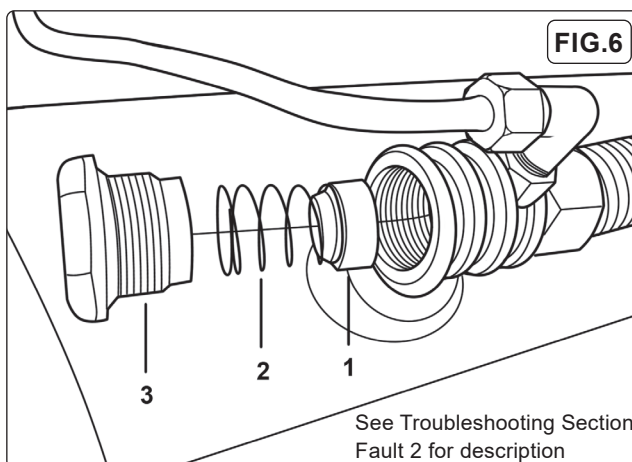

cutting in and out as required to restore the air pressure in the tank. The pressure switch (fig.5.8) stops the motor when the maximum tank pressure is reached and restarts it when pressure falls below the minimum threshold - approx. 2 bar (29psi) less than the maximum pressure.

NOTE: a) If the motor does not cut in and out, but runs continuously when using an air appliance, the capacity of the compressor may be too small for the appliance.

b) Main gauge (fig.5.6) indicates the pressure inside main tank, **NOT** pressure supplied to the air equipment, which is shown on the smaller gauge (fig.5.5). Should pressure in the main tank exceed pre-set switch (fig.5.8) maximum, the safety valve (fig.5.7) activates.

- ❑ **WARNING! For this reason DO NOT tamper with, or adjust, the switch or the safety valve.** When the compressor is not being used set the regulated pressure to zero so as to avoid damaging the pressure regulator.
- 5.9. To stop the compressor press down the main switch (fig.5.1). When the compressor stops there will be a whistling sound as compressed air is vented from the compressor head. **DO NOT**, other than in an emergency, stop the compressor by switching off the mains power, or by pulling the plug out, as the pressure relief will not then occur and motor damage may result upon restart.
- 5.10. When you have finished using the compressor unplug the unit from the mains power supply.
- 5.11. Set the outlet pressure on the regulator to zero.
- 5.12. Remove the air line and air tool.
- 5.13. The tank must now be drained. This will release the air left in the tank and drain away condensation that may have formed within the tank. Choose a suitable location for this operation and/or make provision to collect the condensation. **Wear ear and eye protection.** Open the tank drain valve (fig.3) slowly, allowing air and moisture to bleed from the tank. After bleeding, close the drain valve to prevent debris building up in the valve.
- ❑ **WARNING! Water that is allowed to remain in the tank during storage will corrode and weaken the air tank, which could cause the tank to rupture. To avoid serious injury, drain the tank on a daily basis.**

5.14. SAFETY FEATURES

THERMAL CUT OUT If the unit overheats the thermal cut out will operate and shut the unit down. Allow the unit to cool down.

- 5.15. **NON-RETURN VALVE** (fig.6) Non-return valves (also called check valves) maintain line pressure in the event of unexpected compression, preventing contamination of the process, protecting equipment against damage and improving safety.

6. MAINTENANCE

- ❑ **WARNING!** Before performing any maintenance operation, switch the compressor off, disconnect from electricity supply and release all air from the tank. In order to keep the compressor in good working condition, periodical maintenance is essential.

NOTE: Restrict availability of keys or tools to skilled or instructed persons only.

- ❑ **IMPORTANT WARNING!** Air contaminants taken into the compressor will affect optimum performance. Example: Body filler dust or paint overspray will clog the pump intake filter and may cause internal damage to pump/motor components. Please note that any parts damaged by any type of contamination will not be covered by warranty.

6.1. OPERATIONS TO BE CARRIED OUT DAILY:

- a) Drain condensation, place a container under the valve and open the valve by turning anti-clockwise (fig.3). Retighten the valve.
- b) Check that all nuts and bolts are tight, particularly those retaining the crankcase and cylinder head.
- c) To drain filter regulator, place a container under the bowl and pull down the valve stem.

6.2. OPERATIONS TO BE CARRIED OUT EVERY 100 HOURS: (or more frequently, if the compressor operates in a very dusty atmosphere):

- 6.2.1. Remove the air filter element by unscrewing the filter holder (fig.4) and prising open the holder. Clean it by blowing through with an air line at low pressure, from the clean side. Alternatively, wash it in soapy water, rinse and dry. **DO NOT** operate the compressor without the filter as foreign bodies or dust could seriously damage the pump.

6.2.2. SAFETY VALVE NOTE: When checking the safety valve ALWAYS wear safety glasses.

- 6.2.2.1. To check the operation of the safety valve the air tank will need to be full. Unscrew the valve cap and gently pull it outwards. This should release air under pressure. Release the valve cap and this should stop the air out flow immediately (fig.7).
- 6.2.2.2. If the safety valve does **NOT** work in this manner, **STOP** the air compressor immediately and have the air compressor checked / serviced by an authorised service centre.

6.3. OPERATIONS TO BE CARRIED OUT EVERY 200 HOURS:

- 6.3.1. Check the automatic cut-out at maximum pressure.

6.4. OPERATIONS TO BE CARRIED OUT EVERY 500 HOURS:

- a) Replace air filters.
- b) Check all tube fittings and electrical connections.

IMPORTANT! Failure to carry out maintenance tasks may invalidate the warranty on your compressor.

- ❑ **IMPORTANT! WARNING! - Air contaminants taken into the compressor will affect optimum performance. Example: Body filler dust or paint overspray will clog the pump intake filter and may cause internal damage to pump/motor components. Please note that any parts damaged by any type of contamination will not be covered by warranty.**

6.5. SCHEDULED MAINTENANCE TABLE

6.6. INSPECTION OF PRESSURE TANK BOTH INSIDE AND OUT

Under the PRESSURE SYSTEMS SAFETY REGULATIONS 2000 it is the responsibility of the owner of the compressor to initiate a system of inspection that both defines the frequency of the inspection and appoints a person who has specific responsibility for carrying out the inspection.

NOTE: When performing any maintenance on the unit clearly and prominently display the symbols and wording below.



DO NOT START



**MAINTENANCE
WORK IN
PROGRESS**

7. TROUBLESHOOTING

- ❑ **WARNING!** Before performing any troubleshooting operation, switch the compressor off, disconnect from electricity supply and release all air from the tank. In order to keep the compressor in good working condition, periodical maintenance is essential.

FAULT	CAUSE	REMEDY
1A) Pressure drop in the tank.	Air leaks at connections.	Run compressor to max. pressure, switch off. Brush soap solution over connections and look for bubbles. Tighten connections showing leaks. If problem persists contact Authorised Service Agent.
1B) Pressure drop in the tank.	Air leaks from safety valve.	Operate the safety valve manually by pulling on the ring. If valve continues to leak when in the closed position it should be replaced.
1C) Pressure drop in the tank.	Air leaks from cylinder head gasket.	Check tightness of head bolts. If leak continues contact Authorised Service Agent.
2) Pressure switch valve leaks when compressor is idle.	Non-return valve seal defective.	Empty the air tank. Referring to fig.6, remove the non-return valve cap (3), spring (2) and seal (1). Clean the seal and its seat, or if necessary replace the seal and refit.
3) Air leaks from tank body or tank welds.	Internal corrosion caused by infrequent tank draining or non permitted modifications to tank.	Tank could rupture or explode. Cannot be repaired. DISCONTINUE USE IMMEDIATELY.
4A) Motor stops and will not restart.	Thermal cut out has operated.	Allow unit to cool for 30 mins, then restart.
4B) Motor stops and will not restart.	Supply fuse has tripped.	Reset fuse and restart unit. If repeated tripping occurs, replace the check valve or contact Authorised Service Agent.
5) Compressor stops and does not restart.	Motor failure.	Contact Authorised Service Agent.
6A) Compressor does not stop at max. pressure.	Pressure switch fault.	Contact Authorised Service Agent.
6B) Compressor does not stop at max. pressure.	Filter clogged. Head gasket or valve fault.	Replace filter element. Contact Authorised Service Agent.
7) Compressor noisy with metallic knock.	Bearing or piston damage.	Contact Authorised Service Agent.
8) Excessive moisture in discharged air.	High humidity environment.	Drain tank after each use.



ENVIRONMENT PROTECTION

Recycle unwanted materials instead of disposing of them as waste. All tools, accessories and packaging should be sorted, taken to a recycling centre and disposed of in a manner which is compatible with the environment. When the product becomes completely unserviceable and requires disposal, drain any fluids (if applicable) into approved containers and dispose of the product and fluids according to local regulations.



Note: It is our policy to continually improve products and as such we reserve the right to alter data, specifications and component parts without prior notice.

Important: No Liability is accepted for incorrect use of this product.

Warranty: Guarantee is 12 months from purchase date, proof of which is required for any claim.

Jack Sealey Ltd t/a Sealey Group, Kempson Way, Suffolk Business Park, Bury St Edmunds, Suffolk, IP32 7AR UK
Jack Sealey (EU) Ltd t/a Sealey Group, Farney Street, Carrickmacross, Co. Monaghan, A81 PK68 Ireland
Tel: 01284 757500 • **Email:** sales@sealey.co.uk • **Web:** www.sealey.co.uk